

DIMENSIONS

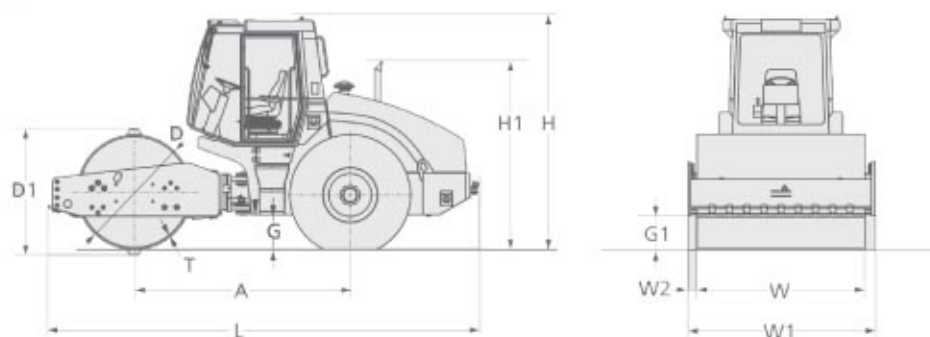

	RP12 (mm)		RP12 (mm)
A	2820	H1	2375
D	1440	L	5686
D1	1640	T	20
G	420	W	2200
G1	430	W1	2436
H	3030	W2	118

SPECIFICATIONS

MAKE	Ammann ASC110D
WEIGHTS	
Operating weight CECE	11495 kg
Operating weight (maximum)	12865 kg
Static linear load	32.4 kg/cm
Front axle load	7130 kg
Rear axle load	4365 kg
DRUM AND WHEELS	
Working width	2200 mm
Drum diameter	1500 mm
Shell thickness	25 mm
Compacting width (maximum)	2200 mm
	Mitas 23.1 - 26
ENGINE	
Engine make	Cummins
Type	QSB 5.9-C155
Rated power, DIN 6221	116 / 158 kW/PS
DRIVE	
No. of travel speed	4
Max. speed	10.6 km/h
Gradeability with vibration	45 %
STEERING	
Turning radius inside	3050 mm
Steering/oscillating angle	±36/10
VIBRATION	
Amplitudes	1.85 mm
Frequencies	32 Hz
Centrifugal force	277 kN
CAPACITIES	
Fuel	410 litres

SHERRIN Rentals

BRISBANE • DARWIN • TOOWOOMBA • SUNSHINE COAST

132 138

Email - info@sherrinrentals.com.au Web - www.sherrinrentals.com.au

12 Tonne Padded Drum Roller