

SPECIFICATIONS

Type	VEHICLE MOUNTED ELEVATING WORK PLATFORM
Standard	Built to AS1418.10 (interim) 2004 ELEVATING WORK PLATFORMS
Operating height and reach	Rated height: 22.5 metres (working height: 24 metres) Rated reach: 13.6 metres (working reach: 14.2 metres)
Safe Work Load	350 kg
Insulation rating	132 kV
Protection for operators:	Fully enclosed, insulated FRP basket with insulating liner. Rated at 22kV Fly boom constructed entirely from GRP. Rated at 132 kV Lower boom fitted with insulating insert. Rated at 33 kV Acceptance tested to 275 kV

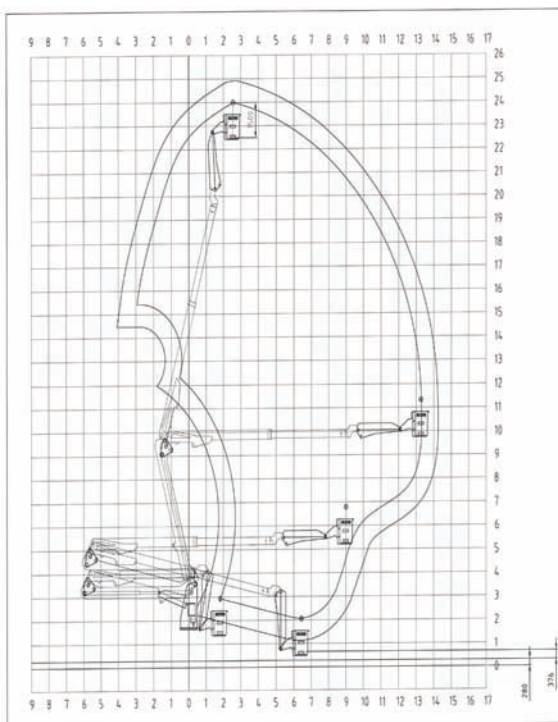

Cab Chassis	Available in 6x4 cab chassis of your choice
Basket	Construction: Glass reinforced plastic with insulating basket liner Insulated and flame retardant to ASTM D635
Basket Rotation	110° rotation (55° left and 55° right) 350 kg SWL
Controls	Basket(main): Radio remote control panel. Operating voltage: 7.2 V dc Turret (auxiliary/emergency): manual controls Back up electric emergency power supply
Safety Controls	24v electric back up pump Manual hand pump allowing full operation Accumulator Hydraulic basket dump
Luffing	Lower boom, upper boom, telescoping boom, jib boom. Hydraulically operated with self-levelling system
Slewing	360° continuous slewing
Stabilisers	4 x hydraulically operated stabiliser legs with self-levelling foot plates comprising: 2 x telescoping front stabiliser legs

SHERRIN Rentals

AUSTRALIA WIDE

132 138

Fax: +61 7 3635 4511

www.sherrinrentals.com.au



24M Glove and Barrier